



## Hydraulic Presses

with structure

- *series C-frame presses*
- *monolithic series*
- *composite series*

[www.omeracom](http://www.omeracom)



## X > HYDRAULIC PRESSES AND MORE...

# HYDRAULIC PRE

## X > AMONGST OUR IDEAS THERE IS DEFINITELY THE RIGHT SOLUTION FOR YOU

OMERA, with its hydraulic presses featuring the unmistakable trademark, stands out against the background of its competitors in a key sector for the mechanical industry. Present on the market since 1951 with its now historic iron-workers, punching machines and trimming-beading machines, the company has since 1970 continued to make its contribution in terms of innovation, experience and advanced technology to the field of sheet metal working.

OMERA has achieved excellent sales results over the years, becoming a leading figure in the industry, remaining ever faithful to the basic ideas of its founder partners and pursuing the increase in technical knowledge within the company and nurturing technical development in hydraulics, electronics, telematics and the components sector. All this has enabled the company to play a new role as a proposer of new solutions and use the most up-to-date and advanced design techniques, in order to give the customers, irrespective of their particular field, the product/service best suited to their needs.

Precisely this close bond that unites OMERa with its customers, is the testimony of a vocation to services, which manifests in the achievement of the best possible performances.



SSES, AND MORE...



SINCE  
1951



## X > **OMERA. SHEET METAL WORKING TECHNOLOGY BECOMES AUTHENTICALLY VERSATILE.**

X Handed down from generation to generation, knowledge and experience acquired in the field have become the company's fundamental heritage and at the same time, a wealth to be shared by all our customers.

The need for the hydraulic press user to be competitive cannot be neglected and this aspect has an ever greater influence on our everyday work at OMER, and consequently in the design of the

most appropriate solutions.

Technical and technological versatility has therefore left the realm of good intentions to enter with full credits into OMER's list of strategic objectives, with the aim of proposing not only formally valid and reliable products but products that are destined to become significant in terms of quality and able to combine technology with the highest performances required by the end-user.



# TECHNOLOGY BECOMES



The versatility of the hydraulic presses when used as a single unit, and the ease with which they can be fitted into a production line enhance their performance capabilities, making them conceptually entirely different from a normal machine tool.

The technological solutions proposed improve their structural solidity, ergonomics and silent functioning at high performances.

## HYDRAULIC C-FRAME PRESSES

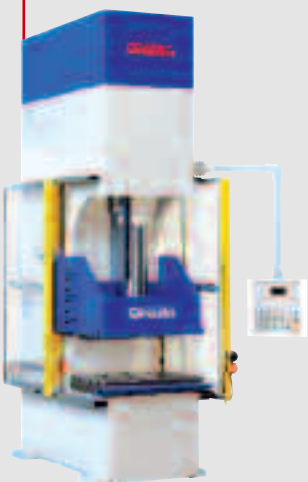

## HYDRAULIC MONOLITHIC PRESSES



## HYDRAULIC COMPOSITE PRESSES



## X > **OMERA.** PROJECTS THAT LOVE CHALLENGES.

# OMERA. PROJECTS T

## X > **TECHNOLOGY**

The favourable reception the presses have enjoyed on the market was due, amongst other things, to the considerable investments made by OMERa in technology intended as a combination of means, instruments and resources, whose optimal use has enabled the company to constantly make improvements from within.

It is this integration of experience and methodology that radically alters our relations with customers because our objective is to customise, rendering the work just as useful as it is necessary to bring real progress to the requirements and wishes of our customers.



# THAT LOVE CHALLENGE

## X > RESEARCH AND DEVELOPMENT

In order for presses to truly become containers of infinite high-performance solutions, the company's "know-how" must be oriented and finalised towards the innovation of processes and products. Interpretation of the user's needs and the transformation of these into ever more appropriate solutions renders this particular task of the company more important and decisive than ever as far as the result is concerned.

This is a "capability" of OMERÀ that is constantly being refined, also through specific and well-aimed training programmes designed for the human resources employed in the company.

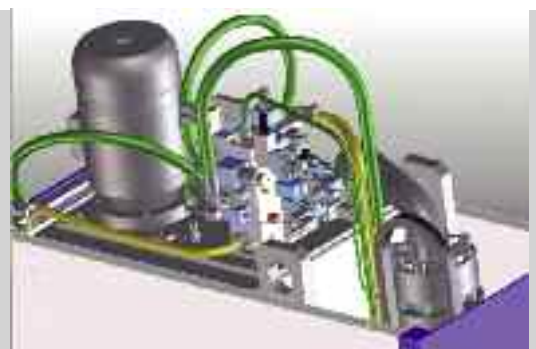
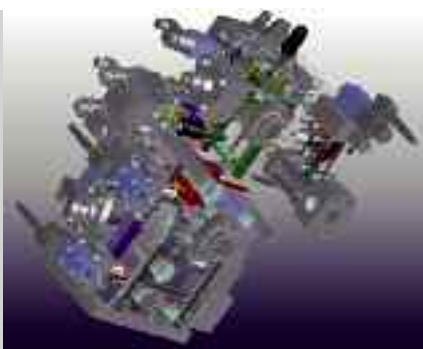
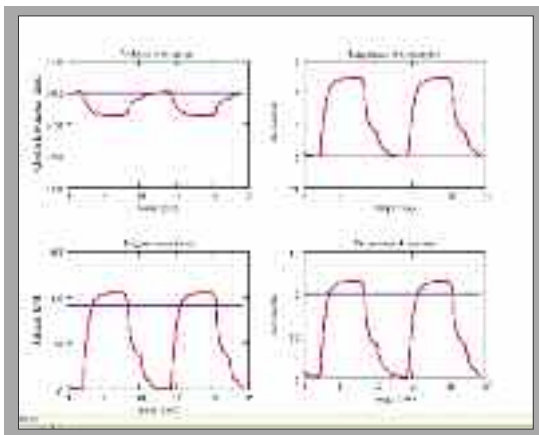
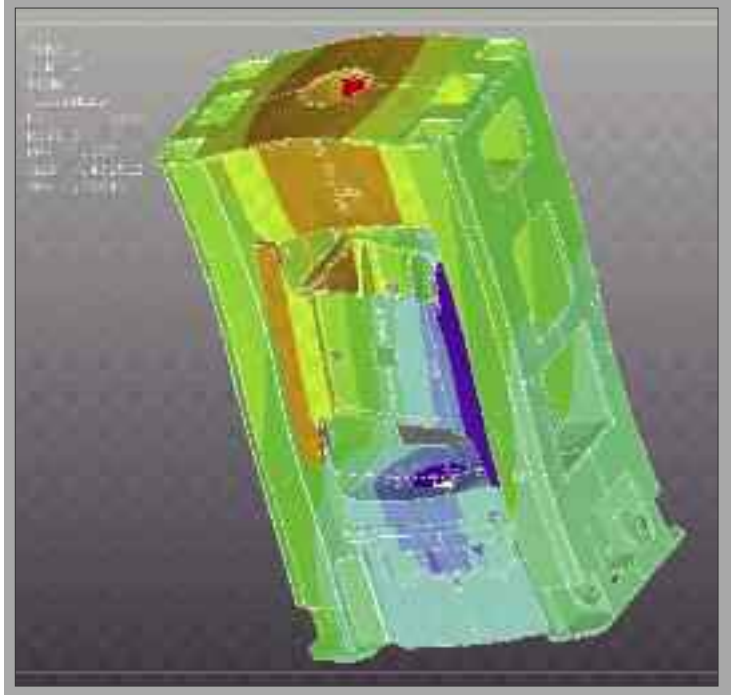

## X > **OMERA.** A TRULY SPECIAL PRODUCTION PROCESS.

# TRULY SPECIAL PROD



OMERA occupies a leadership position in the development on a worldwide scale of technology, applications and services connected with sheet metal working.

By integrating its experience and working synergistically with other companies in the group, OMERa has been able to familiarise itself in depth with all the technical and production problems as well as the true needs of the industry, creating the very best conditions in which to provide the right answer for every customer.

With time, the demand for quality in this field has evolved considerably as a natural consequence of the changes taking place in the international market scenario.

For this reason, OMERa is the first in line to adapt the manufacturing techniques used in its production cycle and, at the same time, to perfect both working methods and processes through developing its technology.

Every OMERa press, and likewise the lines, are constructed at the highest levels of functionality using a complete, rigorous production programme covering the entire manufacturing cycle.

Assembly, carried out in the factory in Chiuppano, and supported by the most advanced working technology available on the market today, enables the construction of presses with the highest levels of efficiency.

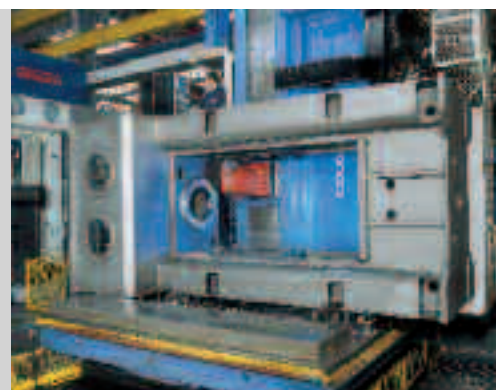



# DUCTION PROCESS.



## X > QUALITY CONTROL

Quality control is of strategic importance for OMER as it is part of the development of an on-going programme that complies with the requirements of standard UNI EN ISO 9001/2000 in order to maintain company competitiveness by consistently improving the product, service and processes.

Amongst the factors that have led to the unquestionable international success of the company through the presses, undoubtedly quality research on the product, in terms of performance and reliability, the competitiveness of its prices and the development of innovative solutions aimed at achieving ever better levels of quality at competitive costs and within set timescales play a significant role.



## X > TESTING

The presses are subject to continuous, rigorous tests carried out both during the various machining stages and after the final assembly.

This testing is carried out following the criteria laid down by the most advanced international standards using specialised personnel to guarantee end-users the very best working performance of the machines they have purchased.



## X > OMER A. QUALITY OF SERVICE. QUALITY IN PERFORMANCE.

# QUALITY OF SERVICE

## X > SERVICE

Gaining the confidence of customers and becoming their inseparable partners means providing a complete and specialised service along with an excellent product.

Dialogue with the end-users of our products is an essential condition for setting in motion the growth process we need in order to pursue our mutual aims for improvement.

For 50 years service has been our real competitive edge. The experience we have acquired and being at our customers' disposal to follow them step by step, from the design stage to the stated performance controls, is OMER A's true strong point.

For OMER A service means creating value through a series of complementary activities, which can be summarised as follows:

### > INSTALLATION

The proven experience as well as recognised skills of OMER A's technicians become evident during the installation and start-up stage of every single new press, as well as during checks on site that performance complies with the original project.

### > ASSISTANCE

Both from the head offices and the around 40 partner agencies spread all over the world, OMER A guarantees the users of its presses continuous assistance and the possibility of speaking directly to an attentive, qualified person who is able to give advice about their requirements.

### > PROGRAMMED MAINTENANCE

This is the formal obligation that OMER A undertakes to each and every one of its customers. Through programmed periodic inspections and check ups, we have achieved the objective of maintaining installations in perfect efficient working order over time preventing downtime and supplementary maintenance.

### > TRAINING

To be used to its best, every OMER A plant installed requires the user to be properly trained. Training of these personnel is a service within the service that OMER A provides on site through its qualified technicians.



# QUALITY IN PERFOR

## X > APPLICATIONS

In the stage prior to the choice of a press, it is advisable to examine all the ranges of products you intend to manufacture and consider how they may evolve in the future. In this stage it would also be appropriate to consider those aspects connected with hourly production rates and production batches. The wide choice of classes and models available enables the presses to be utilised in a vast range of applications, of which these are some of the most common: 1) Simple drawing or drawing in several stages in sequence (re-drawing); 2) Blanking and punching; 3) Coining; 4) Embossing; 5) Bending; 6) Assembly work; 7) Extrusion.

Whatever your requirements are, thanks to the long, corroborated experience we have acquired over time, our technical staff will be able to analyse and recommend you the most suitable product and solutions.

Here below we have illustrated the general concepts on which the OMER A project is based.



## X > STRUCTURE

In all the presses models, machine rigidity is considered of the utmost importance so that flexure under full load is reduced, to guarantee perfect working order of the equipment throughout its life. For this reason, the design stage is followed by a finite element simulation (FEM) test.

After the welding process, the steel structure is subject to a controlled-cycle stress-relieving process that serves to stabilise the structure to prevent breakage over time due to residual tensions caused by the weldings and to guarantee the machine's geometric stability over time. The structure is then sand blasted.

Machining is carried out on modern CNC machines to guarantee maximum precision.

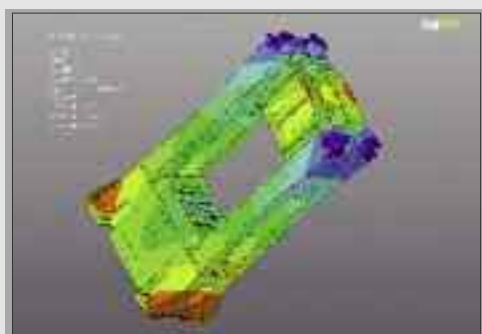

## X > GUIDE TO CHOOSING A QUALITY HYDRAULIC PRESS.

# GUIDE TO CHOOSING

### X > CYLINDERS

The cylinder unit is one of the critical elements of the hydraulic press and this is why Omera always pays particular attention to the finishes of these components.

They are made of forged steel, carefully machined and lapped and checked by ultrasound.

The pistons are made of excellent quality steel, ground and chrome-plated to lengthen the life of the seals.



### X > HYDRAULIC SYSTEM

The adoption of the most sophisticated hydraulic and electronic technology together with long experience of their application enable us to produce high-performance plants with proven reliability over time.

The hydraulic system controls the machine functions of the various actuators and also performs the function of cooling and filtering the oil.

The use of proportional valves enables performance to be maximised by adapting to the particular needs of the dies used, ensuring high speed and accuracy whilst maintaining an enviable smoothness of movement.

The pump capacity can be adjusted and the use of automatic regulators allows power output to be maximised according to the conditions in which it is used.

During the design and construction stages, particular attention is paid to solutions concerning noise emission. Research carried out in this area enables us today to deliver particularly quiet machines.

The tanks have inspection windows for submerged apparatus.

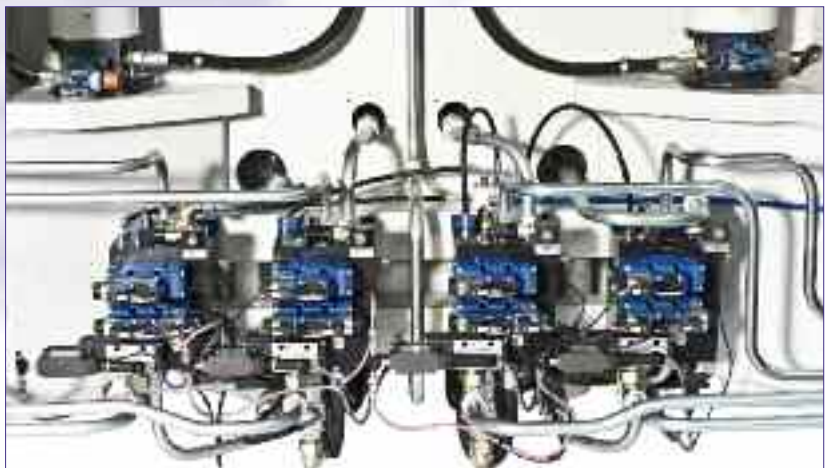
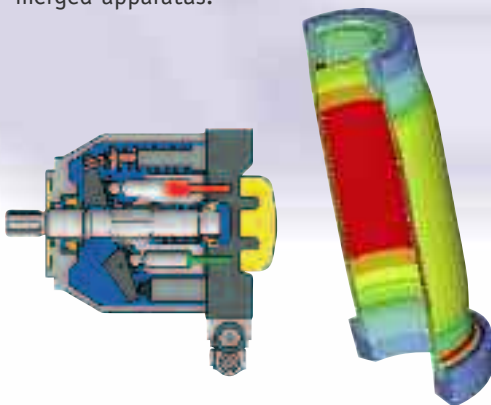

# A QUALITY HYDRAULIC

## X > MACHINE FUNCTION

The following function cycles are normally provided: manual, automatic and adjustment.

In the manual, i.e. single cycle, the operator provides for loading and unloading the pieces, while during the automatic cycle this function is performed by an automation.

The adjustment cycle is used to carry out tests and setting up the equipment.

On a double-acting conventional press, the main stages of a work cycle include the rapid approach of the slide, the work stroke and rapid return of the slide and blank-holder cushion and intervention of the ejector. The cushion may perform the upstroke at the same time as the slide or be delayed.

The following functions are also provided:

- limitation of main slide capacity
- limitation of working speed, for particular drawing operations
- continuous variation of the blank-holder cushion reaction capacity
- coining controlled by a timer

Some applications require different work cycles to the conventional ones, of which the following are just a few examples:

- with upper triple action (both active and passive)
- with drawing from the bottom
- with reversible hydraulic system, to be able to draw both from the top and the bottom
- with independent blank-holder cushion, to reduce working times
- with programmed entry devices (e.g. alternate punching)

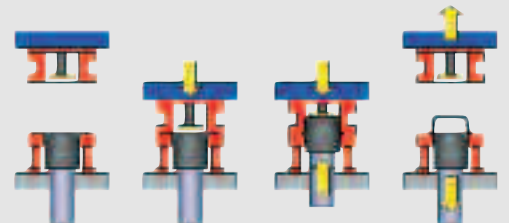

## X > ELECTRICAL SYSTEM

The electric and electronic command and control devices are housed in a cabinet separate from the press. The components used are of high quality to provide maximum reliability and guarantee long life over time.

The process is managed by the use of a programmable computer system while press safety is managed using electromechanical logic.

The dimensions of the cabinets allow considerable free space for any future additions to the machine and provide very effective ventilation. On request, air conditioning systems can be installed.

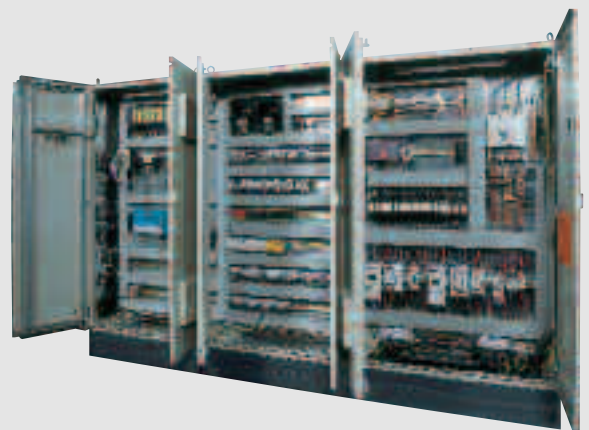

# GUIDE TO CHOOSING

## X > CONTROL SYSTEM

### > CNC description

Apart from some versions of the C-frame press series, where it can in any case be fitted as an optional, all the presses are managed by a CNC device, which in the basic version enables the following parameters to be controlled and managed:

- Memorisation of 200 programmes
- Machine function cycles
- Control of slide stroke
- Control of blank-holder cushion stroke
- Control of the ejector depending on slide stroke
- Control of auxiliary cams for external automations
- Control of lubrication device
- Control of production with piece-counter for two batches
- Control of stopping ramps and speed
- Value offset (equipment maintenance)
- Machine diagnostics with help on line

Communication between the operator and the machine takes place through a video system and user-friendly keyboard. The machine can be programmed directly by means of the keyboard or through self-learning and the parameters can be varied during the work cycle.

The positions are read by absolute digital encoders.

A CNC is used to manage as many as six different pressures of the blank-holder cushion, depending on its position, as well as the normal functions.

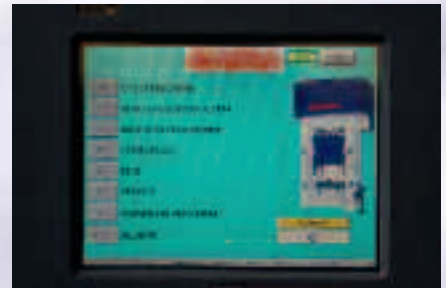
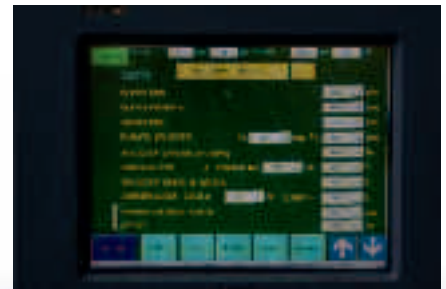

# A QUALITY HYDRAU

## > PC description

On request, a new-generation industrial PC, capable of running the following parameters, as well as those described above can be applied:

- Unlimited memorisation of programmes with floppy disk back up
- Overseeing pressure trends
- Managing slide locking device
- Managing automatic equipment loading/unloading cycles
- Speed management
- Managing production of pieces in several batches
- Complete diagnostics of the hydraulic system, PLC input and output, electronic cams and references to proportional valves
- Interface for connection to the "Ethernet" network
- Modem cards for teleservicing
- Alarms with help videos and complete explanations, historic logs, page helps



# GUIDE TO CHOOSING

## X > SAFETY AND CE CERTIFICATION

OMERA has always paid particular attention to safety problems regarding both the operator and the machine.

This frame of mind has developed over the years thanks to the considerable quota of the product going for export and the design office's co-operation with a number of different standards approval boards; OMERa is therefore today able to offer the market one of the safest products of its kind.

Protections for the operator are:

- highly sensitive photo-electric barriers
- electrically-controlled mobile protections
- fixed side protections
- intrinsic hydraulic safety locks with redundant control
- locking of the slide in position at T.D.C.
- two-hand control where photo-electric barriers are not provided
- specially designed hydraulic circuits and sound-proof panels to minimise noise emissions
- ergonomically-designed machines for safe and perfect accessibility

Appropriate protection systems are also provided to prevent damage caused by improper use or malfunctioning as well as for the safety of the machine.



## X > ACCESSORIES

A truly vast and tested range of accessories to make the machine more flexible and more productive. The versatility of OMERa presses is an "ingredient" made-to-measure after choosing the final result together with our clients.

Here are just a few examples:

- Rapid Die Change: clamps, lifting rails, brackets, trolleys
- Industrial PC
- Low noise hydraulic unit
- Blanking shock-absorbers, both at stroke end and at several intervention points
- Automation/automatic line interface, set up for external protections
- Regenerative or independently activated cushion
- Cooling by means of air heat exchangers
- Triple action and fourth action (both active and passive)
- Reversible circuit for drawing from the top or the bottom
- Mobile trolleys or tables





# A QUALITY HYDRAU



# X > SERIES C-FRAME PRESSES

# SERIES

## X > QUALITY AS STANDARD

Besides being machined on modern machines tools, our presses are assembled in series. This enables us to optimise quality controls as well as the production process and provide **you with a highly reliable product.**

## X > HIGH PRODUCTION PERFORMANCE

Constant updating of the product and the use of advanced technology enable productivity to be increased. Our presses offer you **the chance to lower your production costs.**

## X > A WEALTH OF ACCESSORIES PROVIDED

The C-frame series of presses comes **already complete** with a large number of accessories. In fact, the hydraulic ejector, timer-controlled coining, locking of the slide in position, heat exchanger cooling, pump with automatic power limiting, diagnostics, etc. are all supplied along with the machine.

## X > EASY MAINTENANCE

The design concepts, the experience accumulated over many years of manufacturing presses, the centralised layout of the control organs as well as clear and detailed instructions **will facilitate the maintenance of these presses.**



# C-FRAME PRESSES



# X > SERIES C-FRAME PRESSES

# SERIES

## X > APPLICATIONS

Used both as a single unit and as part of a line – for example with the trimming-beading machines – fed manually, automatically or by means of transfer - C-frame presses are typically used in the production of:

- stainless steel pots and pans
- Teflon-coated aluminium pans and frying pans
- filters and cartridges
- gas bottles and camping accessories
- expansion containers
- pump components
- drinks containers

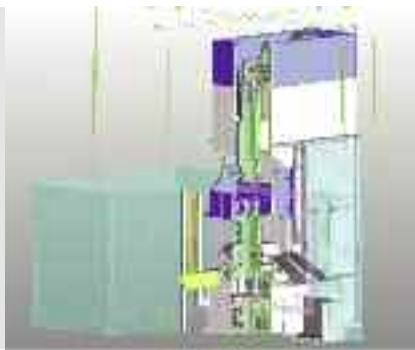
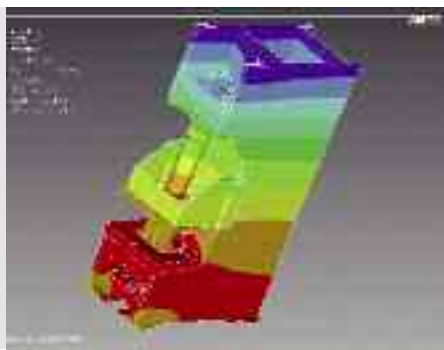

# C-FRAME PRESSES

## X > TECHNICAL DATA

<input type="checkbox"/> > MODEL		OPI.C-50	OPI.C-80	OPI.C-80V	OPI.C-125	OPI.C-125V	OPI.C-160	OPI.C-160V	OPI.C-200V
<b>Slide capacity</b>	<b>kN</b>	500	800	800	1250	1250	1600	1600	2000
<b>Cushion capacity</b>	<b>kN</b>	200	315	315	500	500	650	650	800
<b>Slide stroke</b>	<b>mm</b>	400	600	600	600	600	650	650	650
<b>Cushion stroke</b>	<b>mm</b>	200	250	250	250	250	300	300	300
<b>Distance table/slide</b>	<b>mm</b>	800	1000	1000	1000	1000	1000	1000	1000
<hr/>									
<b>Table surfaces</b>	<b>mm</b>								
600 x 500		•							
750 x 600			•	•					
1000 x 750					•	•			
1000 x 800							•	•	•
<hr/>									
<b>Installed power</b>	<b>kW</b>	<b>Working speed * [mm/s]</b>							
7,5	15 ÷ 45								
15		22 ÷ 60							
15 + 22			55 ÷ 140						
22				20 ÷ 54					
2 x 22					40 ÷ 105				
30						22 ÷ 41			
2 x 30							44 ÷ 82	33 ÷ 67	

\* Characteristics with installed power 50 Hz

# X > MONOLITHIC SERIES

## X > HIGH PRODUCTIVITY GUARANTEED

Thanks to the technology used to **maximise the system's output** as well as allow unconventional machining to be carried out, our presses enable you to reduce your production costs. The choice of the model and appropriate configuration will enable you to meet all your production requirements.

## X > RELIABILITY AND TECHNOLOGY

The quality of construction, experience and technological choices, as well as the components used, make our presses a reliable product. The generous sizing and attention to detail in their mechanical machining are further guarantees of their ability to **carry out repeated production processes** and of the equipment's long life.

## X > A WIDE CHOICE OF ACCESSORIES

The wide choice of accessories available enables you to customise your press according to your specific requirements and benefit from the use of a product built **with these concepts in mind**.

## X > AUTOMAZIONE INTEGRATA

The automatic version of the machine comes out during the design stage. Our presses were created right from the beginning to also function automatically. By adopting an electronic interface, the press is already ready **for connection to any external devices** and to function in complete safety thanks to the presence of protective signalling devices and CE certification.

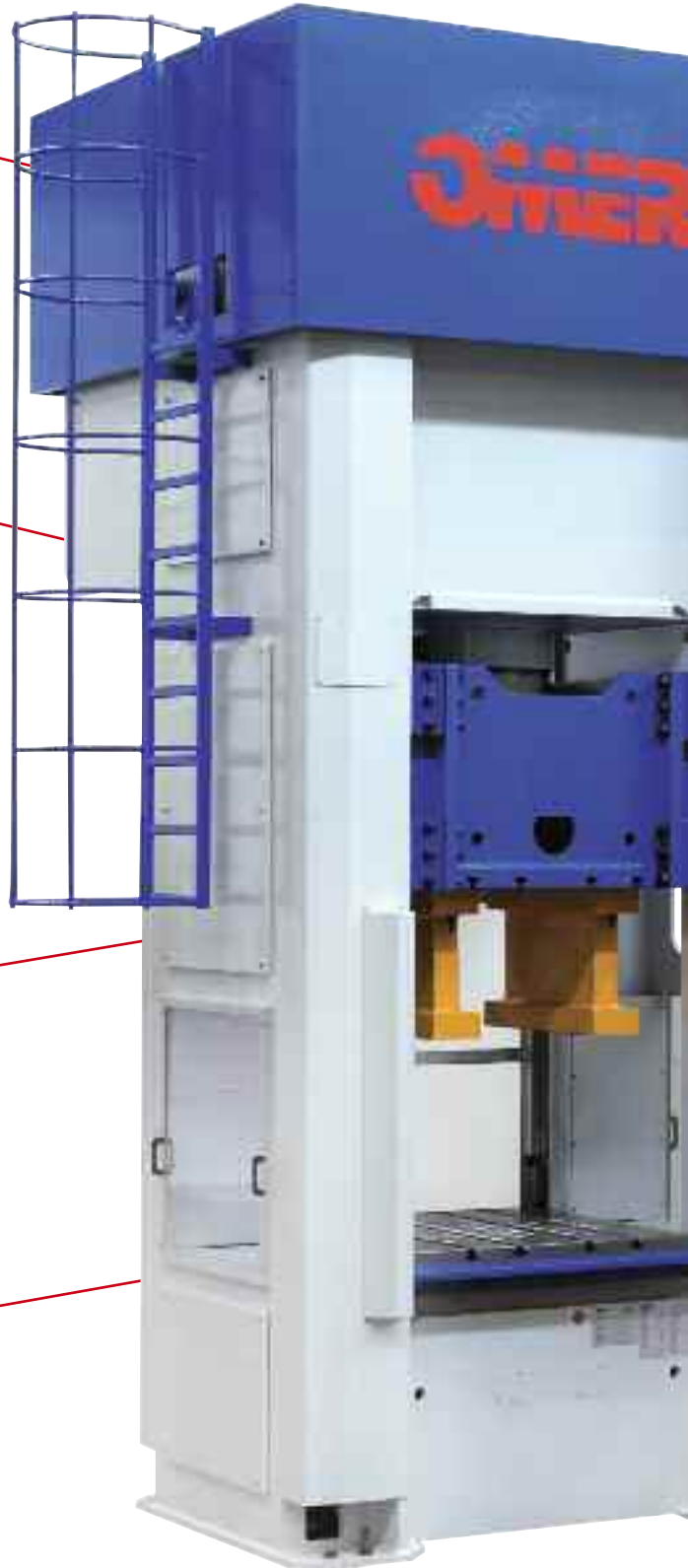

# MONOLITHIC SERIES



# X > MONOLITHIC SERIES

## X > APPLICATIONS

- bottom ends for water heaters and tanks
- cooker tops
- domestic appliances
- drinks containers
- stainless steel pots and pans
- pressurised containers
- gas cylinders
- fire extinguishers

The presses in the monolithic series are widely used in a vast range of applications in a whole host of different industries involving sheet metal working.

The machines can also be supplied complete with dies and automatic feeding systems.





# MONOLITHIC SERIES

## X > TECHNICAL DATA

### MODEL

OPI.M-125 OPI.M-160 OPI.M-200 OPI.M-250 OPI.M-315 OPI.M-400 OPI.M-500 OPI.M-630 OPI.M-800 OPI.M-1000

Slide capacity	kN	1250		1600		2000		2500		3150		4000		5000		6300		8000		10000	
Cushion capacity	kN	500/800		630/1000		800/1250		1000/1600		1250/2000		1600/2500		2000/3150		2500/4000		3150/5000		4000/6300	
Slide stroke	mm	650	800	650	800	650	800	800	1000	800	1000	800	1000	800	1000	800	1000	800	1000	800	1000
Cushion stroke	mm	250	350	250	350	300	350	350	450	350	450	350	450	350	450	350	450	350	450	350	450
Distance table/slide	mm	1000	1300	1000	1300	1000	1300	1300	1600	1300	1600	1300	1600	1300	1600	1300	1600	1300	1600	1300	1600
<b>Table surfaces</b>	<b>mm</b>																				
1000 x 800		•		•																	
1200 x 1100		•		•		•		■		•											
1400 x 1200						•		•		■											
1600 x 1200										•		•									
1600 x 1400												■		•		•					
2000 x 1500													•	•		•		•		•	•
2500 x 1500														•		•		•		•	•
<b>Installed power</b>	<b>kW</b>	<b>Working speed * [mm/s]</b>																			
22	20 ÷ 54																				
2 x 22	40 ÷ 105																				
30				22 ÷ 41		17 ÷ 33															
55				40 ÷ 78		32 ÷ 63		25 ÷ 50		28 ÷ 40											
75								33 ÷ 65		27 ÷ 52		22 ÷ 41		16 ÷ 33		13 ÷ 27		10 ÷ 22		9 ÷ 17	
110								45 ÷ 65		36 ÷ 52		28 ÷ 56		23 ÷ 45		18 ÷ 37		14 ÷ 29		12 ÷ 24	
2 x 75												43 ÷ 83		32 ÷ 66		27 ÷ 54		20 ÷ 43		16 ÷ 34	

\* Characteristics with installed power 50 Hz

■ Normally in stock.

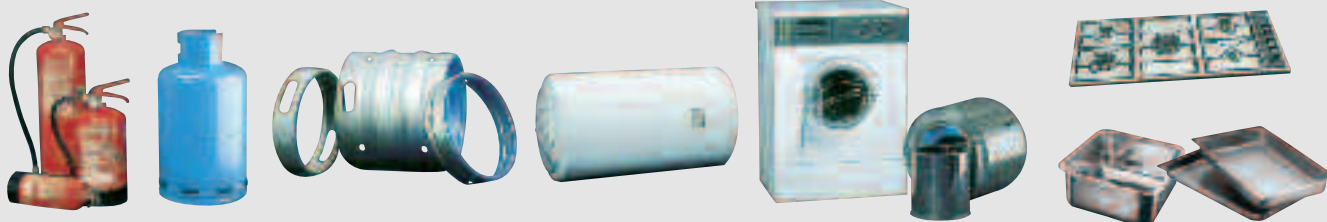

# X > COMPOSITE SERIES

## X > MADE TO MEASURE POWER

Often those who use large-sized hydraulic presses have specific problems to solve, sometimes connected with existing dies, and sometimes with the peculiarity of pieces to be produced. The acknowledged skills of our technicians is to work at our clients' side in order to create projects that satisfy their requirements, even in the future, through suitable customizing interventions.

## X > TECHNOLOGY AND EVOLVING FLEXIBILITY

In a world that is developing continuously and frenetically, new requirements - emerging every day - require us to devise new solutions: alongside our **Research & Development** office we have a series of specialised suppliers who contribute to our efforts to develop and improve our presses in a continuous cycle.

## X > CHOOSING SOLUTIONS

Our ability to listen to what our customers are saying about their requirements, our readiness **to propose alternatives based on experience and innovation** and our ability to identify together with the customer the best way to proceed: these are the qualities that have led us to become a partner for our customers.

## X > GREAT RELIABILITY

Experience and quality cannot be invented but are the fruit of years of work and continuous improvement.

This is why we are proud of the results we have achieved and **the large number of applications** and customers prove it.



# COMPOSITE SERIES



# X > COMPOSITE SERIES

## X > APPLICATIONS

The composite series has been designed for applications in which structural rigidity and flexibility in terms of production are the particular prerogatives required. Machines with several actions from the top or bottom or special solutions enable complex shapes and large dimensions to be achieved in a number of different industries, such as:

- domestic appliances
- car and vehicle bodies
- structural elements
- stainless steel sinks
- cooker tops

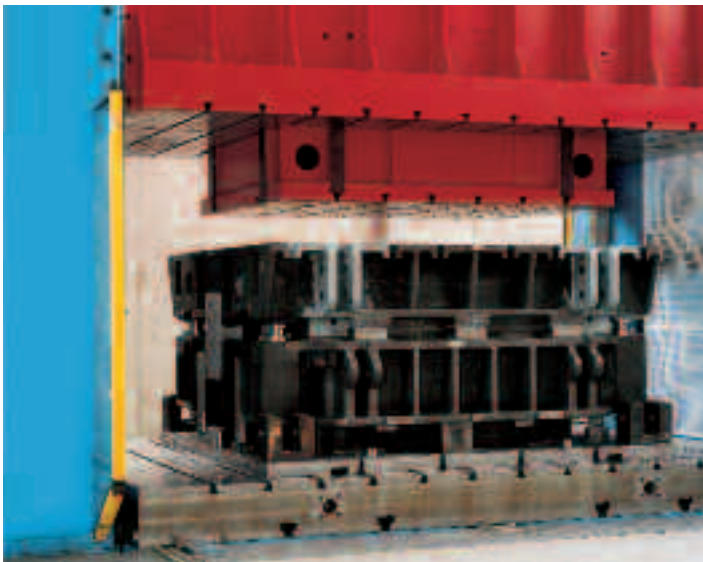
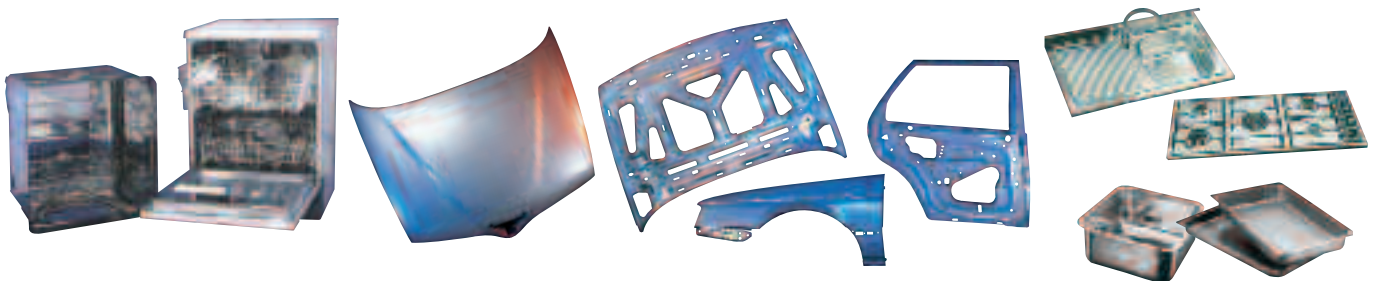

# COMPOSITE SERIES

## X > CARATTERISTICHE

<span style="border: 1px solid red; padding: 2px;"> </span> > MODEL		OPI.T-400	OPI.T-500	OPI.T-630	OPI.T-800	OPI.T-1000	OPI.T-1250	OPI.T-1600	OPI.T-2000
<b>Slide capacity</b>	<b>kN</b>	4000	5000	6300	8000	10000	12500	16000	20000
<b>Cushion capacity</b>	<b>kN</b>	1600/2500	2000/3150	2500/4000	3150/5000	4000/6300	5000/8000	6300/10000	8000/12500
<b>Slide stroke</b>	<b>mm</b>	800   1000	800   1000	800   1000	800   1000	800   1250	1000   1250	1250   1600	1250   1600
<b>Cushion stroke</b>	<b>mm</b>	350   450	350   450	350   450	350   450	350   500	450   500	450   600	450   600
<b>Distance slide/table</b>	<b>mm</b>	1300   1600	1300   1600	1300   1600	1300   1600	1300   2000	1600   2000	2000   2500	2000   2500
<hr/>									
<b>Table surfaces</b>	<b>mm</b>								
1600 x 1400		•	•	•					
2000 x 1500		•	•	•	•	•	•		
2500 x 1500		•	•	•	•	•	•	•	
3000 x 2000				•	•	•	•	•	•
3500 x 2000					•	•	•	•	•
4000 x 2500					•	•	•	•	•
4500 x 2500							•	•	•
5000 x 2500							•	•	•
<hr/>									
<b>Installed power</b>	<b>kW</b>	Working speed* [mm/s]							
75		22 ÷ 41	16 ÷ 33	13 ÷ 27	10 ÷ 22				
110		28 ÷ 56	23 ÷ 45	18 ÷ 37		12 ÷ 24	8 ÷ 19	8 ÷ 15	
2 x 75		43 ÷ 83	32 ÷ 66	27 ÷ 54	20 ÷ 43	16 ÷ 34	13 ÷ 30	9 ÷ 22	8 ÷ 17
2 x 110					30 ÷ 66	24 ÷ 52	19 ÷ 44	14 ÷ 33	11 ÷ 24
4 x 75									15 ÷ 35

\* Characteristics with installed power 50 Hz

## X > FROM THE PRESS TO THE AUTOMATIC LINE.

# FROM THE PRESS

### X > INTEGRATED PRODUCTION PROJECTS

The internal teamwork of a company specialised in the construction of a diversified series of products successfully recognised at international level, the intense structural cooperation with die-makers we trust, the majority share in a company manufacturing special machines, have allowed Omera to achieve the enviable technological background which today enables it to successfully construct reliable, technologically-advanced automatic production lines, and provide a first-class service.

We have achieved perfect integration between our customers and ourselves as suppliers generating all-round growth for both parties, enabling the realisation of a large number of installations in a wide range of different manufacturing industries.



PRODUCTION LINE FOR HOUSEHOLD APPLIANCES PARTS



PRODUCTION LINE OF WATER HEATERS



LINE FOR GPL GAS BOTTLES OF 12 KG



LINE FOR ENDS OF BIG DIMENSIONS

# TO THE AUTOMATIC



PRODUCTION OF ENDS IN STEEL DUPLEX



PRODUCTION OF ENDS FROM COIL IN ZIG ZAG



PRODUCTION LINE OF STAINLESS STEEL KEGS



PRODUCTION LINE OF BOILERS



PRODUCTION LINE OF WATER HEATERS OF BIG DIMENSIONS

## ACCESSORY CHART.

 DESCRIPTION	>OPI.C	>OPI.M	>OPI.T
Protection guards	●	●	●
Photo-electric barriers	○	○	○
Access ladder to press-top	—	●	●
Hydraulic ejector	■	○	○
Passive triple action	○	○	○
Active triple action (drawer)	○	○	○
CNC programmable control and data acquisition	■	■	■
Control with industrial PC	—	○	○
Hydraulic axis at constant speed	○	○	○
Proportional pressure control	■	■	■
Interface for opiLink automation	○	○	○
Blank-holder cushion	■	■	■
Blankholder cushion with independent return	○	○	○
Differentiated pressure blank-holder cushion	—	○	○
Upper blank-holder cushion	—	○	○
Mobile trolley or table	—	○	○
Coining device with timer	■	■	■
Slide locking device	■	■	■
Oil pre-heating	■	■	■
Oil/water heat exchanger	■	■	■
Oil/air heat exchanger	○	○	○
Rapid die change	○	○	○
Blanking shock-absorbers	—	○	○
Additional control pulpit	—	○	○
Blank-holder pressure pins	○	○	○
Bushings pins-guides	○	○	○
Lighting of work area and AC socket	○	○	○
Different painting to standard	○	○	○

**KEY**

● SAFETY

■ STANDARD

○ OPTIONAL

One of Omera's objectives is the continual improvement of its products.

Technical data and characteristics therefore are subject to modifications without prior notice.





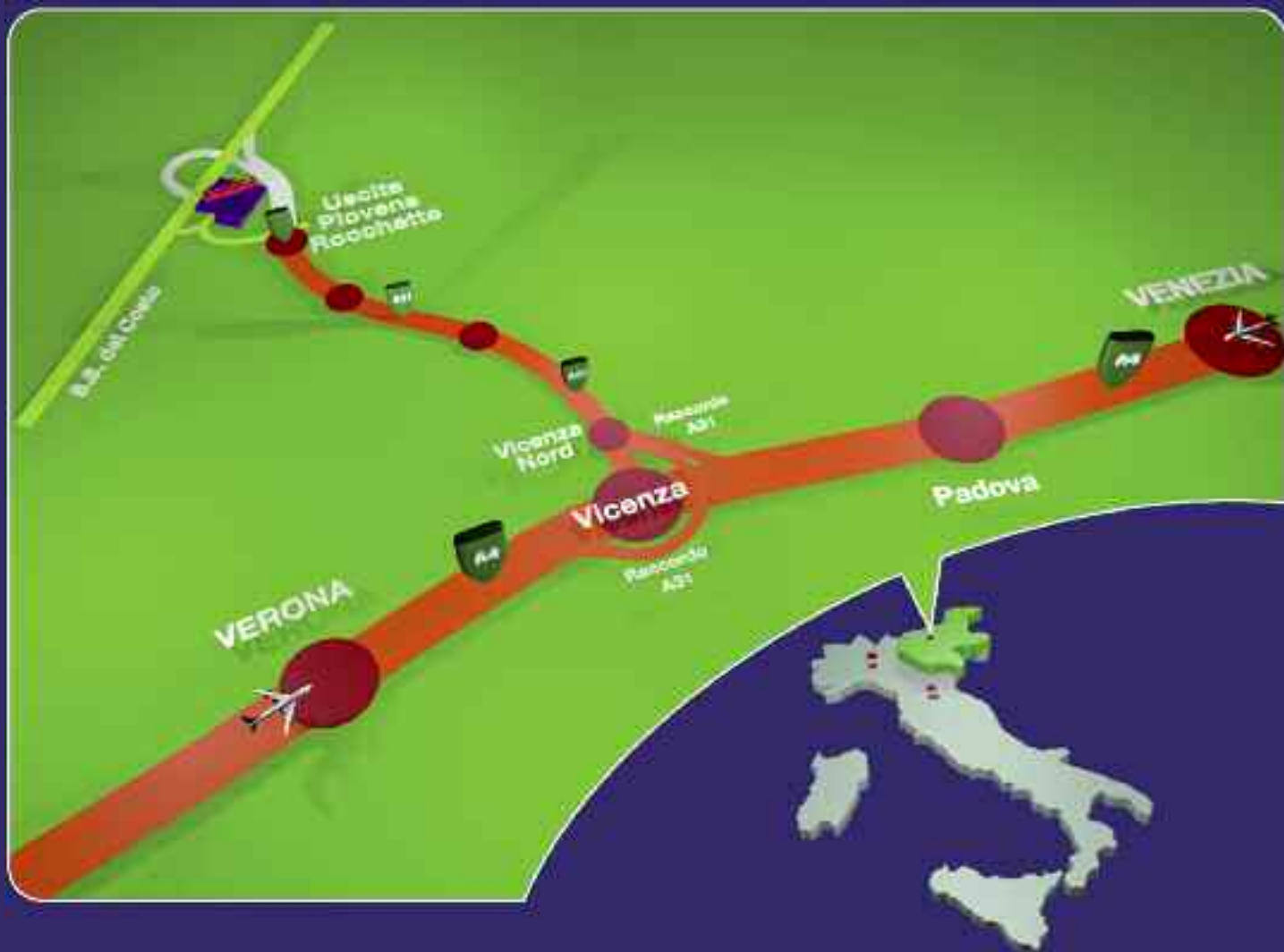

# OMERA

OMERA S.r.l.  
 Via Ponte dei Granatieri, 8  
 36010 Chiappano (Vicenza) Italy  
 Tel. +39 0445 805444  
 Fax. +39 0445 805404  
 ucomm@omera.com



AZIENDA CON SISTEMA DI GESTIONE  
 PER LA QUALITÀ CERTIFICATO DA DNV  
 = UNI EN ISO 9001:2008 =

COMPANY WITH QUALITY MANAGEMENT  
 SYSTEM CERTIFIED BY DNV  
 = ISO 9001:2008 =

[www.omera.com](http://www.omera.com)